

# EC\*3

## ELECTRIC CYLINDERS

SERIES 11

ISO 15552

### DESCRIPTION

- A - Rod guide
- B - Rod
- C - Piston
- D - Nut
- E - Bearing
- F - Coupling
- G - Coupling carter
- H - Screw
- L - Magnetic ring
- M - Barrel
- N - Front cap

— The electric cylinders ECL3 and ECS3 are made with mounting interfaces in compliance with ISO 15552.

— The linear motion transmission is realized by means of precise and with high efficiency ball screws. Screw and nut are made in high resistance hardened steel and have high load capacity, in order to guarantee long life even in demanding applications. The ECS3 series is characterized by a selection of oversized ball screws. This feature maximizes the life of the cylinders and makes them suitable for the most demanding applications.

— The cylinder design is made to minimize vibrations: the piston is precisely guided in the barrel with double zero-backlash sliding guide; the shaft end of the screw is supported by a bearing; the rod is guided into the front head with a long linear bushing.

— The cylinder can be equipped with a robust integrated anti-rotation device.

— The piston is equipped with a magnetic ring and the barrel is equipped with external slots to accommodate any sensors. The rod has an increased external diameter and thickness to maximize rigidity and resistance to radial and buckling loads. The screw is supported by high capacity bearings to allow the transmission of high loads in both directions.

— A high-strength timing belt is used to connect the motor in parallel, in order to have reliability and strength of the torque transmission chain.

— Many pneumatic accessories can be used to fix and mount the electric cylinder, including intermediate trunnions.

### PERFORMANCES

Size		032	040	050	063	080	100	125
Maximum axial force	N	2100	3400	6400	11100	20900	53500	123400
Maximum speed	mm/s	1333	1333	1422	1333	1333	702	533
Maximum acceleration	m/s <sup>2</sup>	8	10	13	16	16	13	13
Standard stroke up to	mm	800	1000	1200	1400	1800	2400	3000
Maximum average axial force for 2500 km life	N	1380	1700	2280	3640	4520	19750	49640
Ambient temperature range	°C	-20 / +100						
Max air humidity allowed for IP65 (without condensation)	%	90						
Protection degree		IP44 or IP65						



### 1 - IDENTIFICATION CODE

<b>EC</b>	<b>3</b>	-	/	-	/	<b>11</b>	-	/	-	<b>/M</b>
Electric cylinders	Series: L = standard S = oversized screw	Dimensional group	Size: 032 = ISO 32 040 = ISO 40 050 = ISO 50 063 = ISO 63 080 = ISO 80 100 = ISO 100 125 = ISO 125	Mounting type: T = front threaded holes (standard) A = front flange (MF1) C = rear clevis (MP2) D = rear eye (MP4) G = feet (MS1) L = intermediate trunnions (MT4)	Rod end: M = male thread (standard) F = female thread C = clevis cap S = spherical cap L = self-centreing coupler X = special	Stroke: max 800 mm for size 032 max 1000 mm for size 040 max 1200 mm for size 050 max 1400 mm for size 063 max 1800 mm for size 080 max 2400 mm for size 100 max 3000 mm for size 125 For longer strokes contact our technical dept.	Screw type: B = ball screw L = lead screw (only for ECL3, sizes 032, 050, 063) Roller screw available upon request.	Screw lead: (see overall dimension tables of each size for availability and matches)	for ball screw 040 = 4 mm 050 = 5 mm 100 = 10 mm 120 = 12 mm 127 = 12.7 mm 160 = 16 mm 200 = 20 mm 250 = 25 mm	for lead screw (see point 11) 040 = 4 mm
Project No. assigned by Diplomatic										
Rod offset: S000 = no offset (standard) S010 = offset 10 mm Custom offset on request										
Motor flange: S = stepper B = brushless G = gearbox Flange for AC or DC motors on request										
Motor position: 0 = 12 o'clock      6 = 6 o'clock 3 = 3 o'clock      9 = 9 o'clock										
Motor mounting flange: (omit if not required) P = parallel (ratio 1 ÷ 1) (standard) L = in line On request, parallel flange with 2:1 ratio or with customized ratio are also available.										
End stroke sensor type (see point 12): 0 = no sensor 1 = PNP normally open (standard) 2 = PNP normally closed 3 = NPN normally open 4 = NPN normally closed										
End stroke sensor pcs.: N = none A = single D = double T = triple Q = quadruple										
Lubrication point: NN = none (compulsory for EC*3-032) F0 = centred 12 o'clock F3 = centred 3 o'clock F6 = centred 6 o'clock F9 = centred 9 o'clock										
Protection class: N = IP44      S = IP65										
Rotation stopper: N = none      P = present										
Series number										

**NOTE: For all items on request you have to contact our sales support.**



## 2 - COMMON TECHNICAL CHARACTERISTICS

ACCURACY		mm	± 0.035
ENVIRONMENT	Ambient temperature range	°C	-20 / +100 ( <b>NOTE</b> )
	Protection class		IP44 or IP65
	Humidity	%	0 ÷ 90
MECHANICAL	Reference standard		ISO 15552
	Duty cycle	%	100
	Internal rotation stopper		available on all sizes
	Rod-end		male or female
	Rod material		chromium-plated (standard) stainless steel upon request
	Mounting		on front cap or with accessories
	End stroke sensor		available on all sizes

**NOTE:** The indicated temperature range refers to the cylinder only, without motor. If the cylinder is equipped with end stroke sensors, the temperature range has to be limited to -10 / +70 °C.

## 3 - APPLICATION FIELDS

EC\*3 electric cylinders are suitable:

- In normal handling systems with ball screws in the automation field, replacing normal cylinders when speed and controlled and constant acceleration or deceleration ramps are required, even under load.
- On all occasions where handling with considerable traction / thrust forces is required but the use hydraulic cylinders is not advisable.
- In handling systems where absence of environmental pollution and / or extreme silence is required.

### 3.1 - Applications

ISO 15552 EC\*3 electric cylinders are the right solution for all those applications that require accurate and controlled positioning. The wide range of sizes, screw diameters and pitches allow you to design modular application solutions, minimizing the design of customized parts.

Easy installation and the range of construction types make the EC\*3 electric cylinders a benchmark for this market segment.

The wide choice among several models makes it possible to use the ECL3 and ECS3 cylinders even in critical applications, offering considerable resistance to static and dynamic loads, significantly heavier than standard market proposals.

The opportunity to share the most of standard ISO 15552 pneumatic accessories with EC\*3 cylinders in the same dimensions is an additional practical and cost advantage in mounting the cylinders.



### 4 - EC\*3-032

#### 4.1 - Technical characteristics

			ECL3		ECS3	
Mechanical	Rod diameter	mm	20		20	
	Rod end		M10x1.25		M10x1.25	
Ball screw	Nominal diameter	mm	12		14	12.7
	Lead	mm	5	10	4	12.7
	Dynamic load	N	6600	4400	6000	8000
Force	Max force (torque) - in line	N (Nm)	2100 (2.0)	2100 (2.2)	2100 (1.6)	2100 (5.0)
	Max force (torque) - parallel	N (Nm)	2100 (2.2)	2100 (4.4)	2100 (1.8)	2100 (5.5)
	Force at 2500 km (*)	N	832	698	702	1375
Speed	Maximum speed	rpm	6667	6667	5714	6299
		mm/s	556	1111	381	1333
Acceleration	Max acceleration	m/s <sup>2</sup>	3.2	6.4	2.5	8.1
Efficiency	In line (parallel)	%	86 (77)	88 (79)	84 (76)	88 (80)

(\*) Dynamic axial force at 2500 km lifetime

#### 4.2 - Service life

The service life depends on average dynamic axial load.

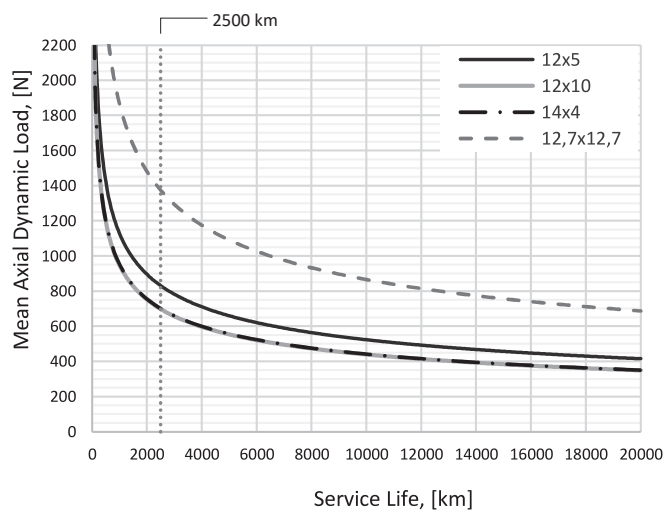

#### NOTES

- Service life is a statistical value and refers to 90% reliability.
- Correct working conditions: i.e. no lateral-load, no overload, right lubrication, no over-temperature, no short-stroke application.
- The permissible axial force is calculated considering a pushing condition with free rod end and fixed barrel constraint. Contact us for different loading applications and for any questions.

#### 4.3 - Permissible speed

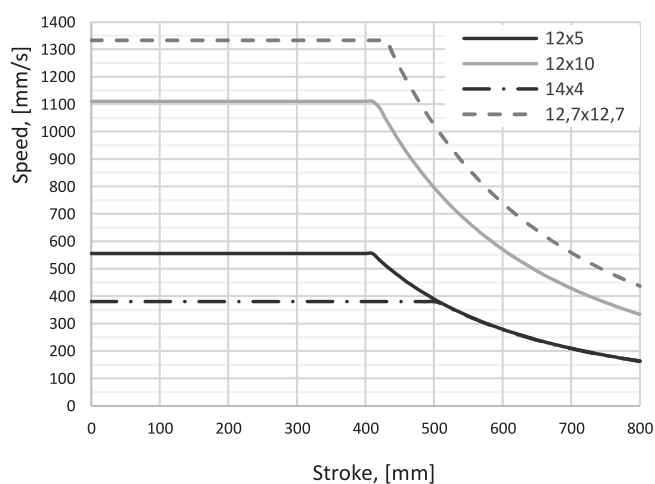

#### 4.4 - Permissible axial force

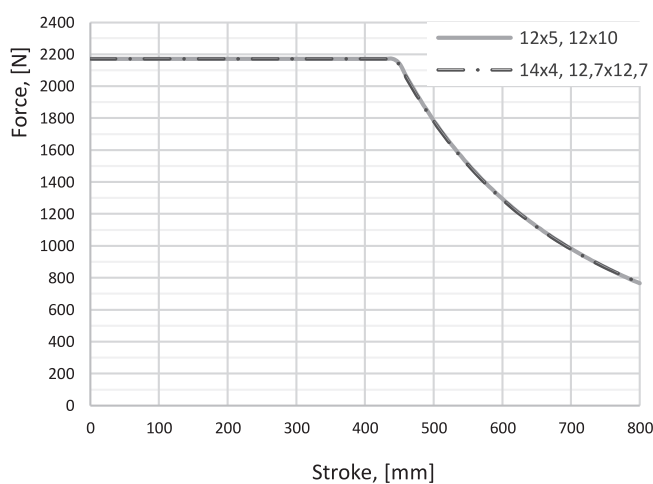



### 4.5 - EC\*3-032 Dimensions

dimensions in mm

#### In-line motor mounting

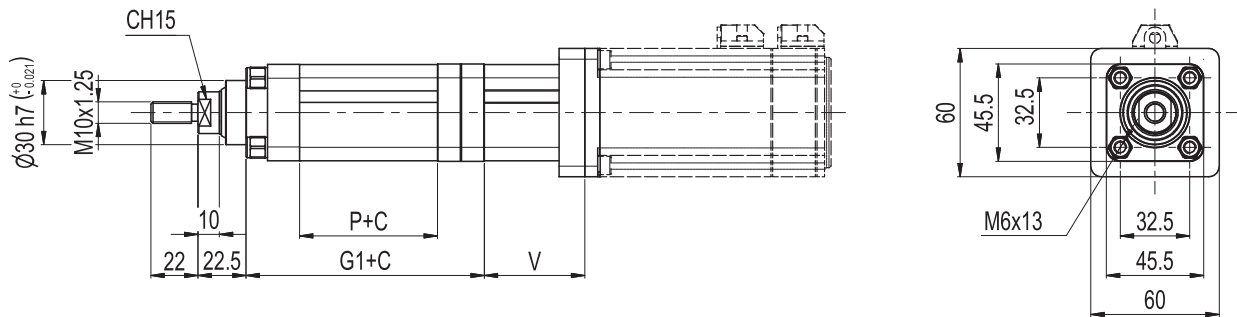

#### Parallel motor mounting

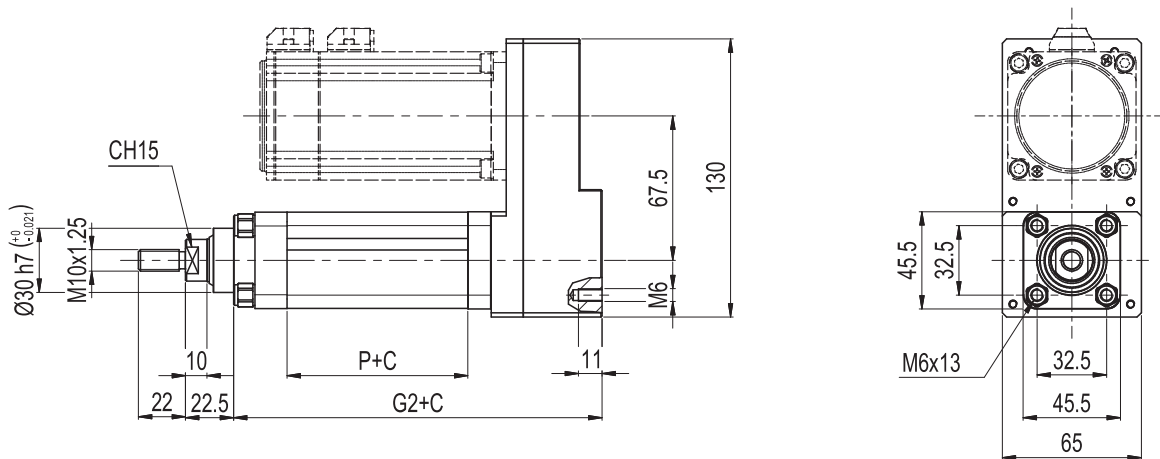

	Ball screw	P	G1	G2
ECL3	12x5	73.5	120.4	161.25
	12x10	73.5	120.4	161.25
ECS3	12.7x12.7	84.5	131.4	172.25
	14x4	64.5	111.4	152.25
	Lead screw	P	G1	G2
ECL3	14x4	64.5	111.4	152.25

C = Stroke value  
V = Depending on motor dimensions



### 5 - EC\*3-040

#### 5.1 - Technical characteristics

			ECL3		ECS3		
Mechanical	Rod diameter	mm	25		25		
	Rod end		M12x1.25		M12x1.25		
Ball screw	Nominal diameter	mm	14	12.7	16		
	Lead	mm	4	12.7	5	10	16
	Dynamic load	N	6000	8000	10104	6112	9150
Force	Max force (torque) - in line	N (Nm)	3000 (2.3)	2400 (5.5)	3400 (3.2)	3400 (6.3)	3080 (8.9)
	Max force (torque) - parallel	N (Nm)	3000 (2.5)	3400 (8.7)	3400 (3.6)	3400 (7.0)	3400 (11.0)
	Force at 2500 km (*)	N	702	1375	1273	970	1699
Speed	Maximum speed	rpm	5714	6299	5000	5000	5000
		mm/s	381	1333	417	833	1333
Acceleration	Max acceleration	m/s <sup>2</sup>	2.5	8.1	3.2	6.4	10.2
Efficiency	In line (parallel)	%	84 (76)	88 (80)	85 (76)	87 (79)	88 (80)

(\*) Dynamic axial force at 2500 km lifetime

#### 5.2 - Service life

The service life depends on average dynamic axial load.

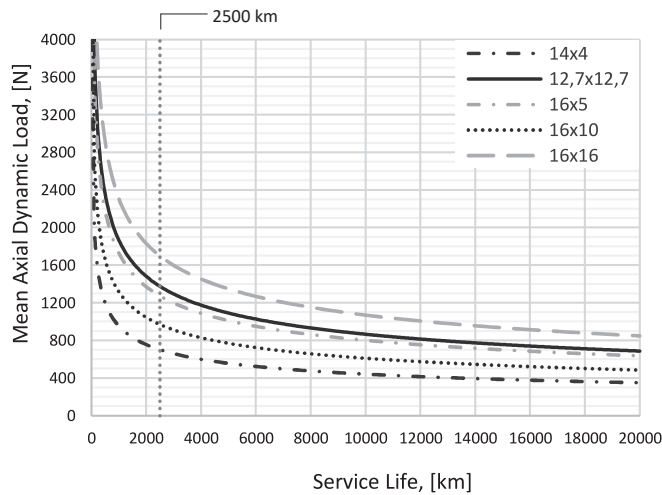

#### NOTES

- Service life is a statistical value and refers to 90% reliability.
- Correct working conditions: i.e. no lateral-load, no overload, right lubrication, no over-temperature, no short-stroke application.
- The permissible axial force is calculated considering a pushing condition with free rod end and fixed barrel constraint. Contact us for different loading applications and for any questions.

#### 5.3 - Permissible speed

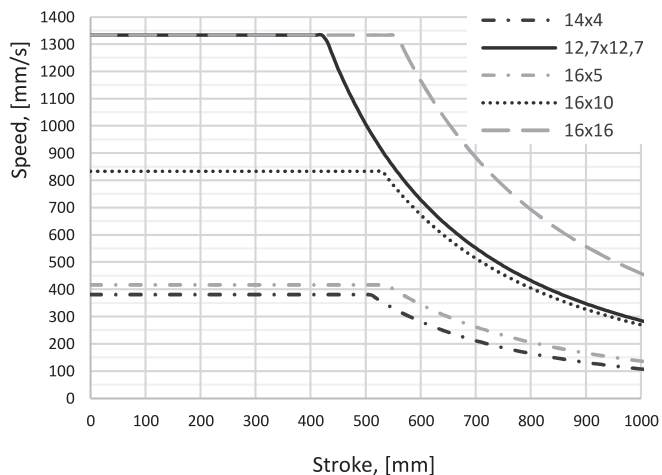

#### 5.4 - Permissible axial force

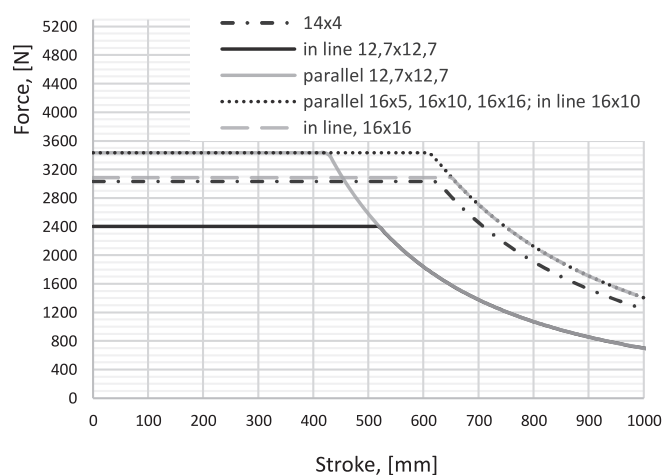



### 5.5 - EC\*3-040 Dimensions

dimensions in mm

#### In-line motor mounting

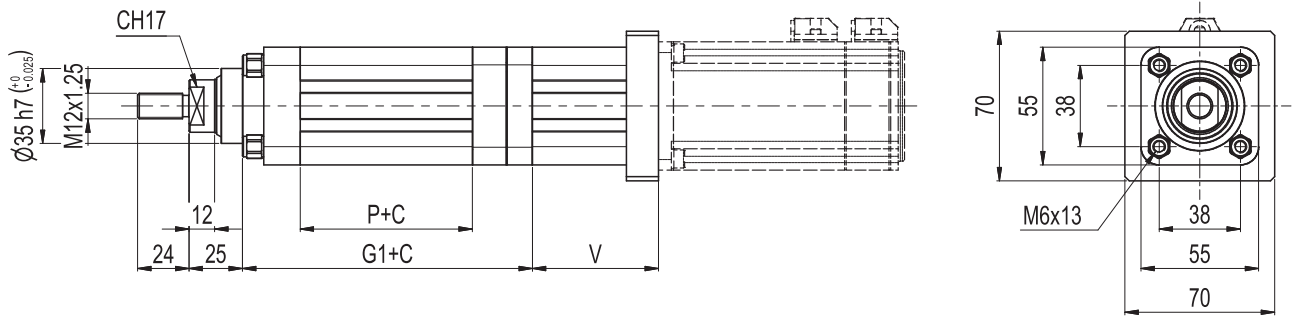

#### Parallel motor mounting

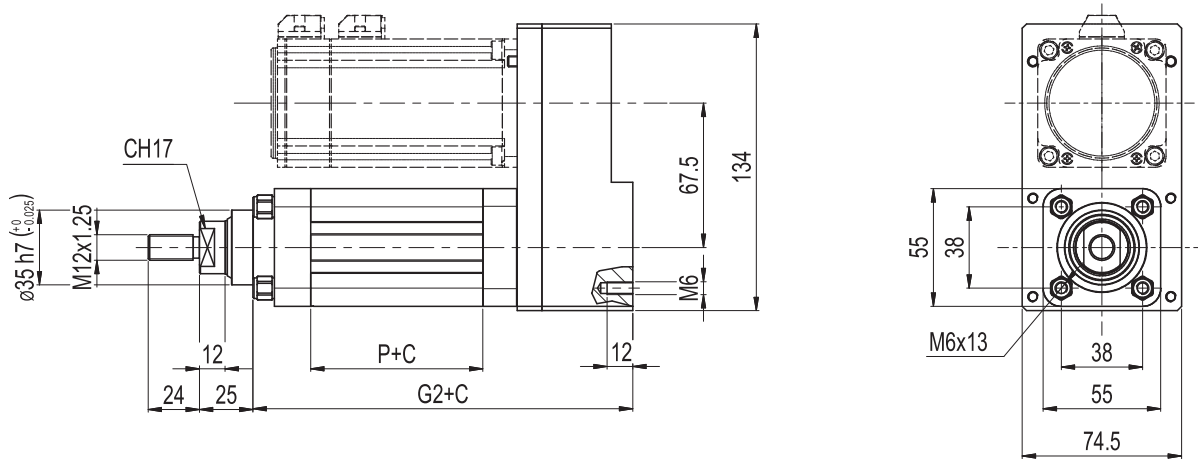

	Ball screw	P	G1	G2
ECL3	12.7x12.7	80.5	135.6	177.6
	14x4	645	119.6	161.5
ECS3	16x5	88	143.1	185.1
	16x10	96	151.1	193.1
	16x16	79	134.1	176.1

C = Stroke value  
V = Depending on motor dimensions



### 6 - EC\*3-050

#### 6.1 - Technical characteristics

			ECL3			ECS3		
Mechanical	Rod diameter	mm	25			30		
	Rod end		M16x1.5			M16x1.5		
Ball screw	Nominal diameter	mm	16			20		
	Lead	mm	5	10	16	5	10	20
	Dynamic load	N	12655	9908	12263	11154	11272	10000
Force	Max force (torque) - in line	N(Nm)	6300 (5.9)	3200 (5.9)	2050 (5.9)	6400 (6.1)	4850 (8.9)	2470 (8.9)
	Max force (torque) - parallel	N(Nm)	6400 (6.7)	5400 (11)	6400 (20.5)	6400 (6.8)	6400 (13.1)	5830 (23.3)
	Force at 2500 km (*)	N	1594	1573	2276	1405	1789	2000
Speed	Maximum speed	rpm	5333	5333	5333	4000	4000	4000
		mm/s	444	889	1422	333	667	1333
Acceleration	Max acceleration	m/s <sup>2</sup>	3.2	6.4	10.2	3.2	6.4	12.7
Efficiency	In line (parallel)	%	85 (77)	88 (79)	88 (80)	84 (75)	87 (78)	88 (80)

(\*) Dynamic axial force at 2500 km lifetime

#### 6.2 - Service life

The service life depends on average dynamic axial load.

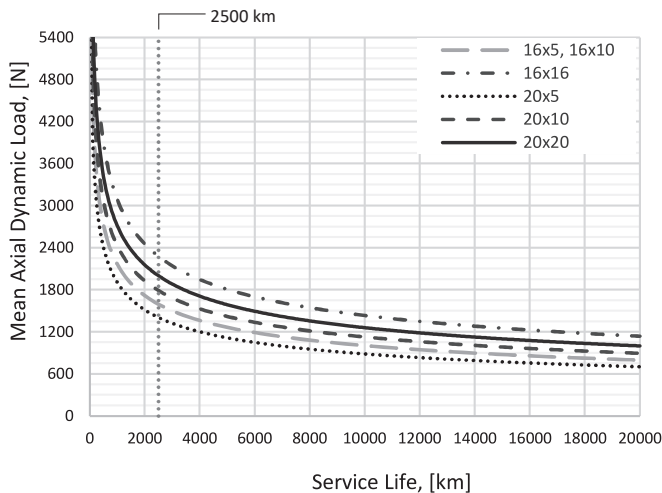

#### NOTES

- Service life is a statistical value and refers to 90% reliability.
- Correct working conditions: i.e. no lateral-load, no over-load, right lubrication, no over-temperature, no short-stroke application.
- The permissible axial force is calculated considering a pushing condition with free rod end and fixed barrel constraint. Contact us for different loading applications and for any questions.

#### 6.3 - Permissible speed

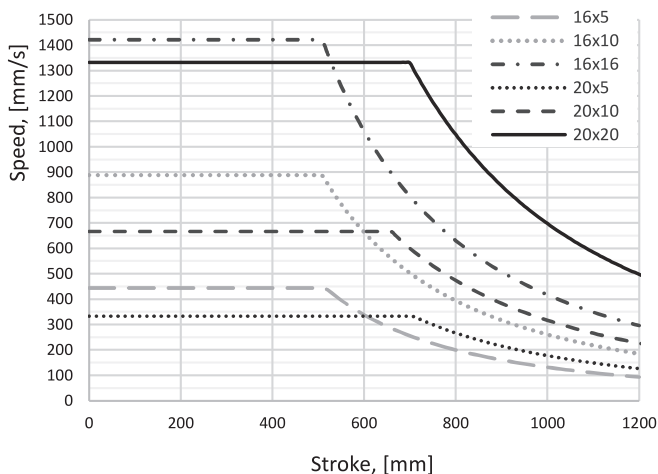

#### 6.4 - Permissible axial force

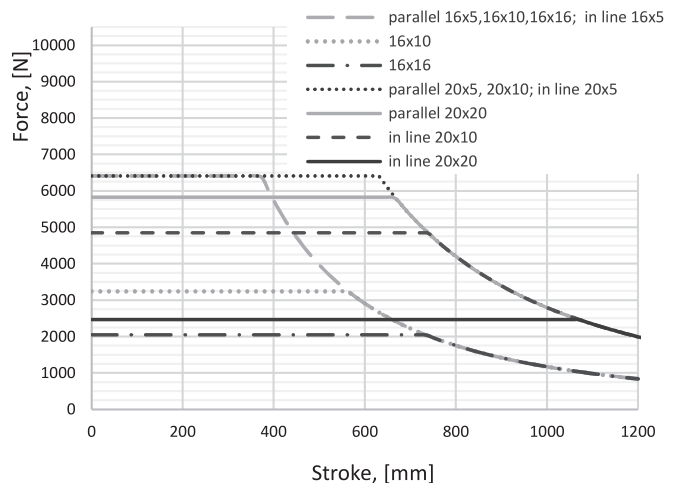



### 6.5 - EC\*3-050 - Dimensions

dimensions in mm

#### In-line motor mounting

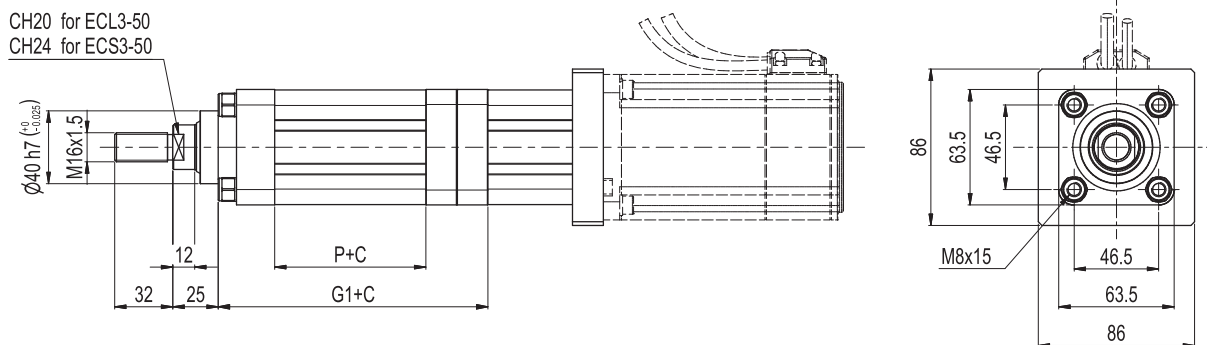

#### Parallel motor mounting

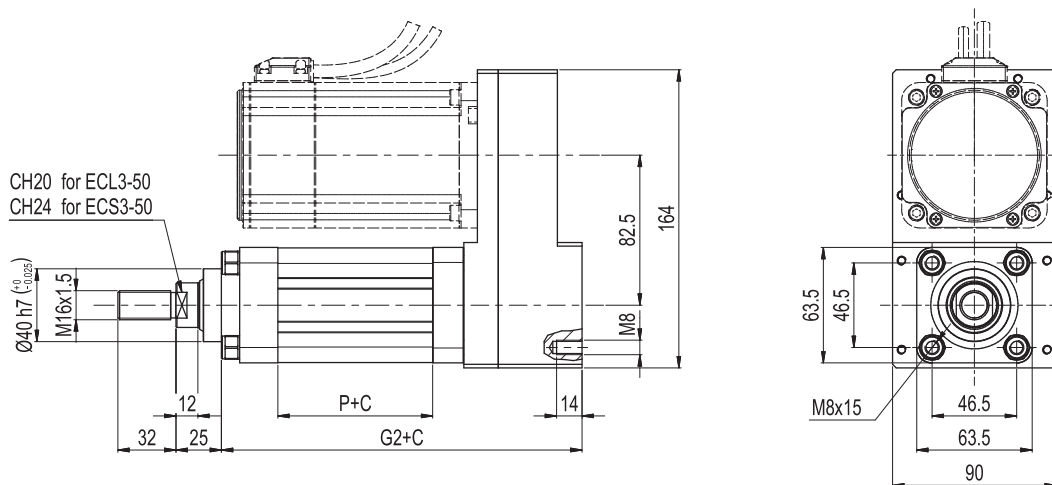

	Ball screw	P	G1	G2
ECL3	16x5	83.2	148.3	196.3
	16x10	83.2	148.3	196.3
	16x16	85.2	150.3	198.3
ECS3	20x5	103.2	168.3	216.3
	20x10	112.2	177.3	225.3
	20x20	96.2	161.3	209.3
	Lead screw	P	G1	G2
ECL3	16x4	75.5	140.6	188.6

C = Stroke value  
V = Depending on motor dimensions



### 7 - EC\*3-063

#### 7.1 - Technical characteristics

			ECL3			ECS3		
Mechanical	Rod diameter	mm	30			35		
	Rod end		M16x1.5			M16x1.5		
Ball screw	Nominal diameter	mm	20			25		
	Lead	mm	5	10	20	5	10	25
	Dynamic load	N	14715	9712	12262	16383	15990	16873
Force	Max force (torque) - in line	N (Nm)	9500 (9.1)	7300 (13.6)	7300 (26.5)	11100 (10.8)	11100 (20.6)	5890 (26.5)
	Max force (torque) - parallel	N (Nm)	9500 (10.1)	7300 (15.1)	7300 (29.5)	11100 (11.9)	11100 (22.9)	5890 (29.5)
	Force at 2500 km (*)	N	1854	1542	2453	2064	2538	3635
Speed	Maximum speed	rpm	4000	4000	4000	3200	3200	3200
		mm/s	333	667	1333	267	533	1333
Acceleration	Max acceleration	m/s <sup>2</sup>	3.2	6.4	12.7	3.2	6.4	15.9
Efficiency	In line (parallel)	%	84 (75)	87 (78)	88 (80)	82 (74)	86 (77)	88 (80)

(\*) Dynamic axial force at 2500 km lifetime

#### 7.2 - Service life

The service life depends on average dynamic axial load.

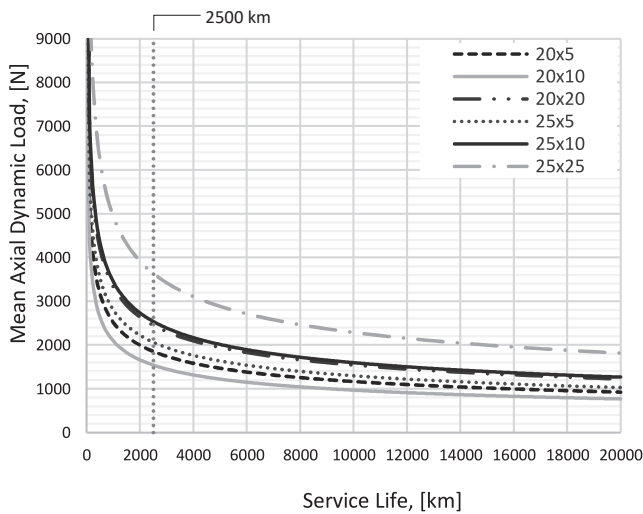

#### NOTES

- Service life is a statistical value and refers to 90% reliability.
- Correct working conditions: i.e. no lateral-load, no overload, right lubrication, no over-temperature, no short-stroke application.
- The permissible axial force is calculated considering a pushing condition with free rod end and fixed barrel constraint. Contact us for different loading applications and for any questions.

#### 7.3 - Permissible speed

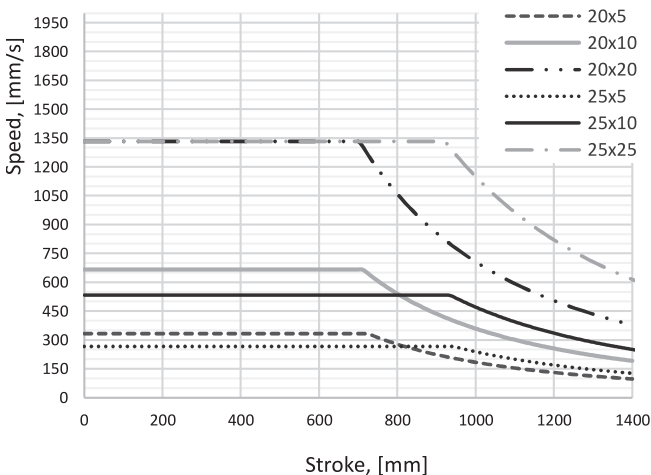

#### 7.4 - Permissible axial force

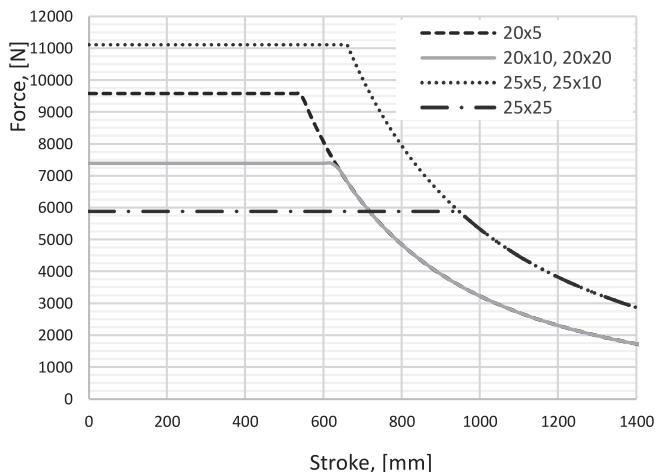



### 7.5 - EC\*3-063 - Dimensions

dimensions in mm

#### In-line motor mounting

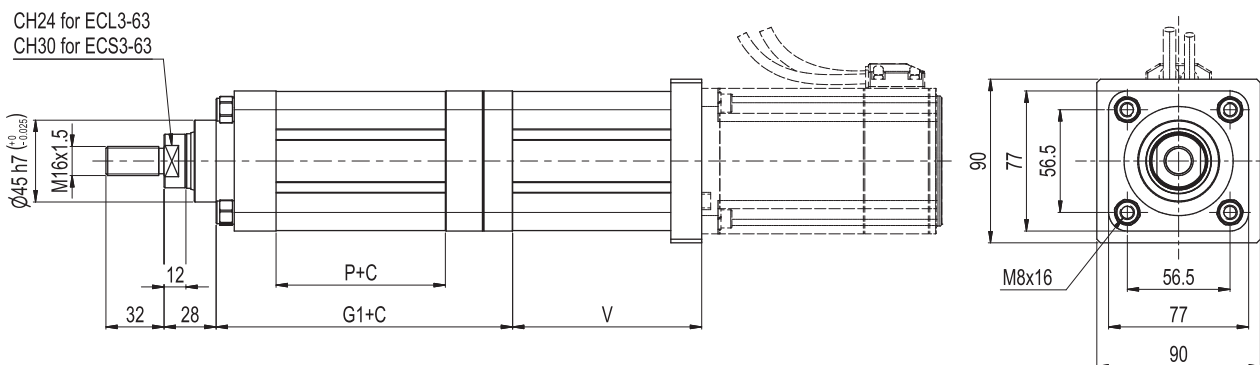

#### Parallel motor mounting

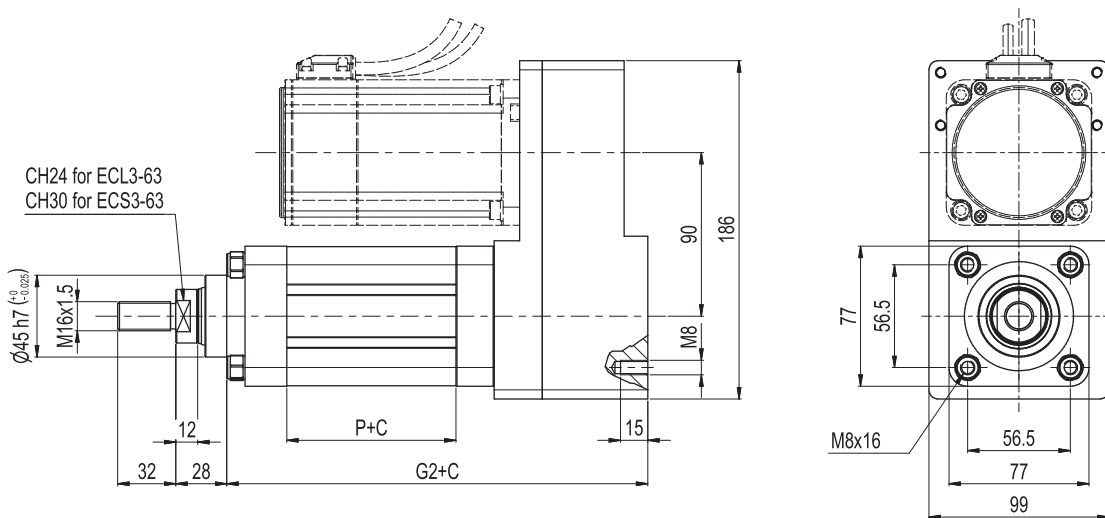

	Ball screw	P	G1	G2
ECL3	20x5	93.1	163.1	231.6
	20x10	93.1	163.1	231.6
	20x20	95.1	165.1	233.6
ECS3	25x5	119.1	194.1	262.6
	25x10	119.1	194.1	262.6
	25x25	119.1	194.1	262.6

	Lead screw	P	G1	G2
ECL3	20x4	93	163	231.5

C = Stroke value  
V = Depending on motor dimensions



### 8 - EC\*3-080

#### 8.1 - Technical characteristics

			ECL3			ECS3		
Mechanical	Rod diameter	mm	45			45		
	Rod end		M20x1.5			M20x1.5		
Ball screw	Nominal diameter	mm	25			32		
	Lead	mm	5	10	25	5	10	20
	Dynamic load	N	16383	15990	16873	15333	28439	20895
Force	Max force (torque) - in line	N (Nm)	12100 (11.7)	11500 (21.3)	9900 (45)	13100 (13)	20900 (39.3)	12300 (45)
	Max force (torque) - parallel	N (Nm)	12100 (13)	11500 (23.7)	12700 (63.8)	13100 (14.5)	20900 (43.6)	15990 (64.7)
	Force at 2500 km (*)	N	2064	2538	3635	1932	4514	4179
Speed	Maximum speed	rpm	3200	3200	3200	2500	2500	2500
		mm/s	267	533	1333	208	417	833
Acceleration	Max acceleration	m/s <sup>2</sup>	3.2	6.4	15.9	3.2	6.4	12.7
Efficiency	In line (parallel)	%	82 (74)	86 (77)	88 (80)	80 (72)	85 (76)	85 (76)

(\*) Dynamic axial force at 2500 km lifetime

#### 8.2 - Service life

The service life depends on average dynamic axial load.

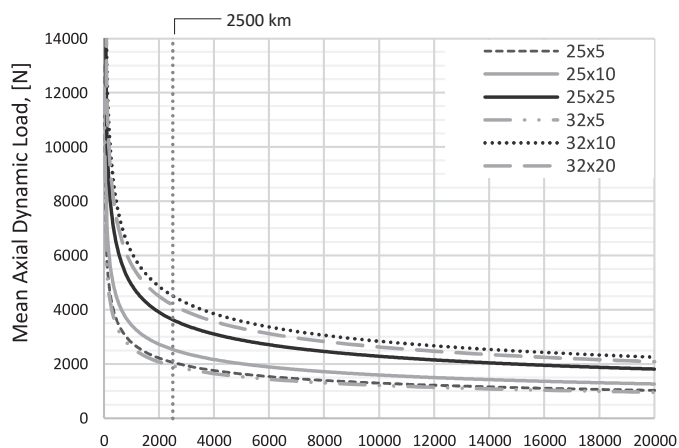

#### NOTES

- Service life is a statistical value and refers to 90% reliability.
- Correct working conditions: i.e. no lateral-load, no over-load, right lubrication, no over-temperature, no short-stroke application.
- The permissible axial force is calculated considering a pushing condition with free rod end and fixed barrel constraint. Contact us for different loading applications and for any questions.

#### 8.3 - Permissible speed

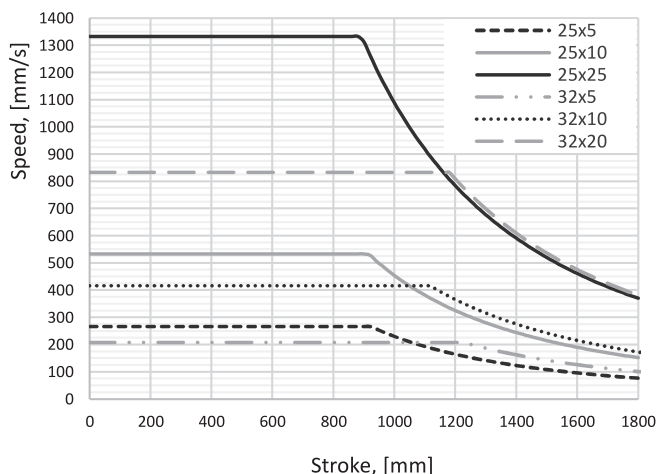

#### 8.4 - Permissible axial force

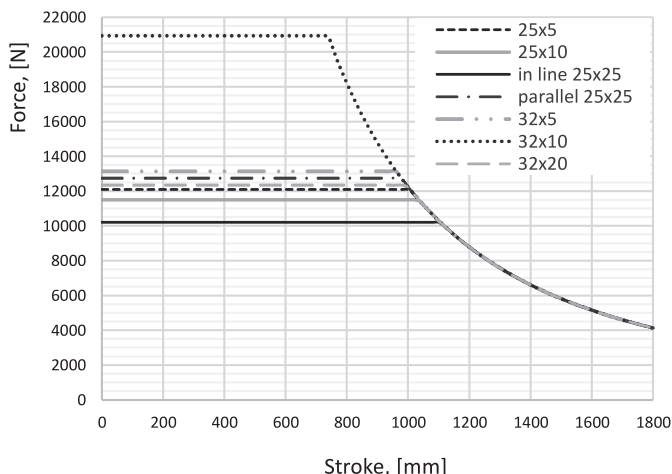



### 8.5 - EC\*3-080 - Dimensions

dimensions in mm

#### In-line motor mounting

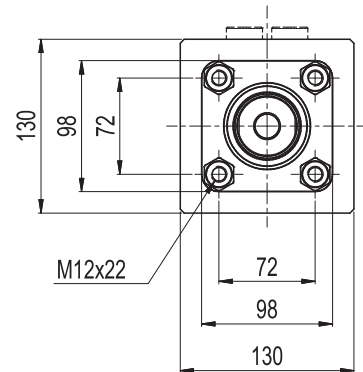
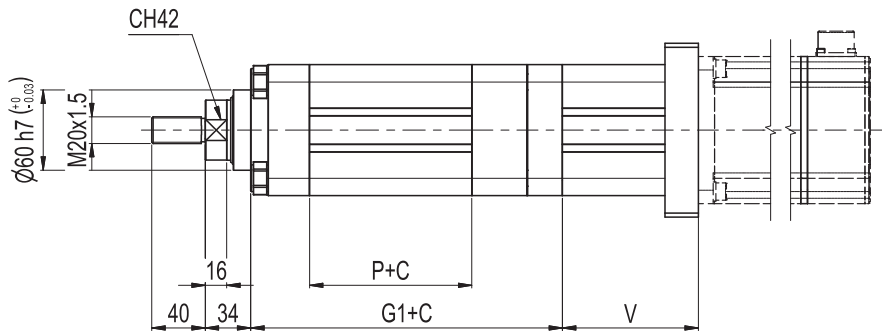

#### Parallel motor mounting

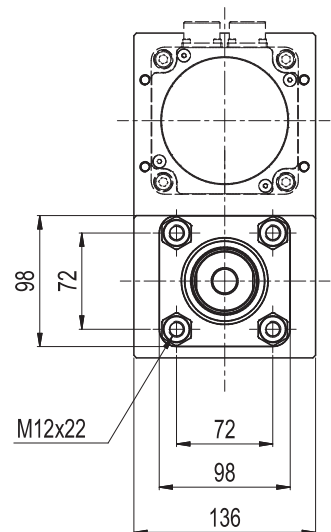
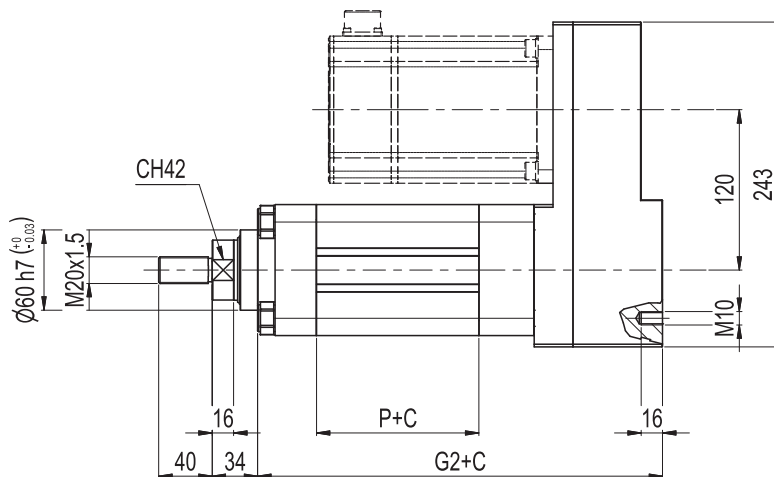

	Ball screw	P	G1	G2
ECL3	25x5	121.4	233.2	302.9
	25x10	121.4	233.2	302.9
	25x25	121.4	233.2	302.9
ECS3	32x5	109.8	221.6	291.3
	32x10	140.8	252.6	322.3
	32x20	136.8	248.6	318.3

C = Stroke value  
V = Depending on motor dimensions



### 9 - EC\*3-100

#### 9.1 - Technical characteristics

			ECL3		ECS3
Mechanical	Rod diameter	mm	70		70
	Rod end		M42x2		M42x2
Ball screw	Nominal diameter	mm	38	38	50
	Lead	mm	10	20	20
	Dynamic load	N	64150	61509	98718
Force	Max force (torque) - in line	N (Nm)	53500 (101.5)	53500 (196.1)	53500 (198.3)
	Max force (torque) - parallel	N (Nm)	53500 (107.9)	53500 (208.6)	53500 (210.9)
	Force at 2500 km (*)	N	12442	12302	19744
Speed	Maximum speed	rpm	2105	2105	1600
		mm/s	351	702	533
Acceleration	Max acceleration	m/s <sup>2</sup>	6.4	12.7	12.7
Efficiency	In line (parallel)	%	84 (79)	87 (82)	86 (81)

(\*) Dynamic axial force at 2500 km lifetime

#### 9.2 - Service life

The service life depends on average dynamic axial load.

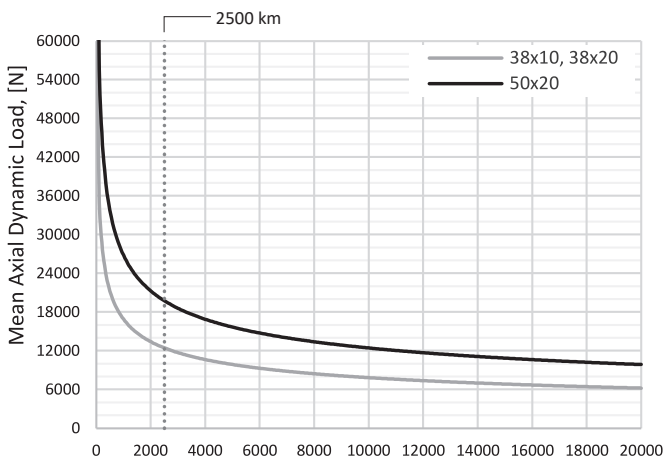

#### NOTES

- Service life is a statistical value and refers to 90% reliability.
- Correct working conditions: i.e. no lateral-load, no over-load, right lubrication, no over-temperature, no short-stroke application.
- The permissible axial force is calculated considering a pushing condition with free rod end and fixed barrel constraint. Contact us for different loading applications and for any questions.

#### 9.3 - Permissible speed

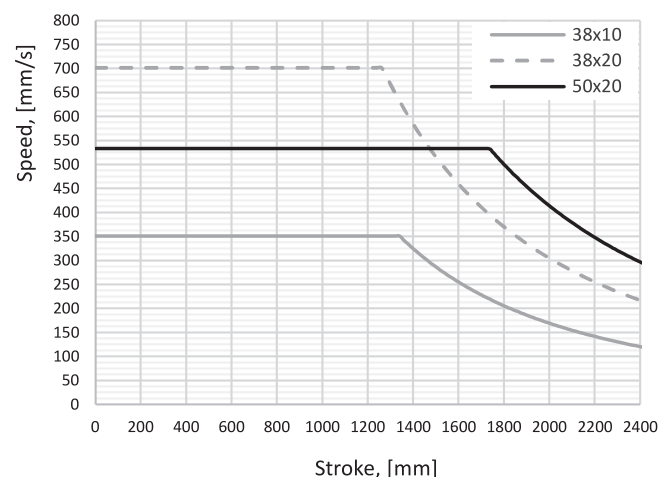

#### 9.4 - Permissible axial force

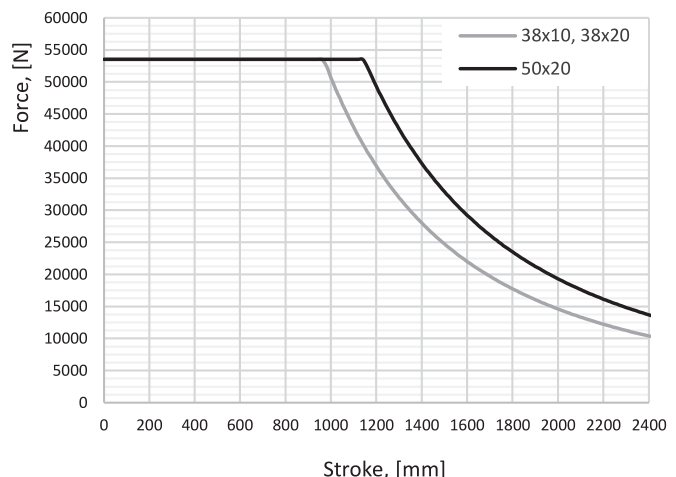



### 9.5 - EC\*3-100 - Dimensions

dimensions in mm

#### In-line motor mounting

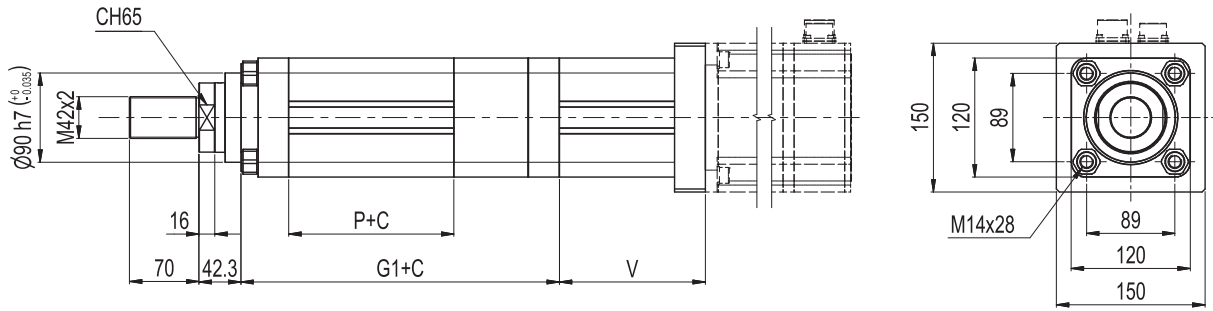

#### Parallel motor mounting

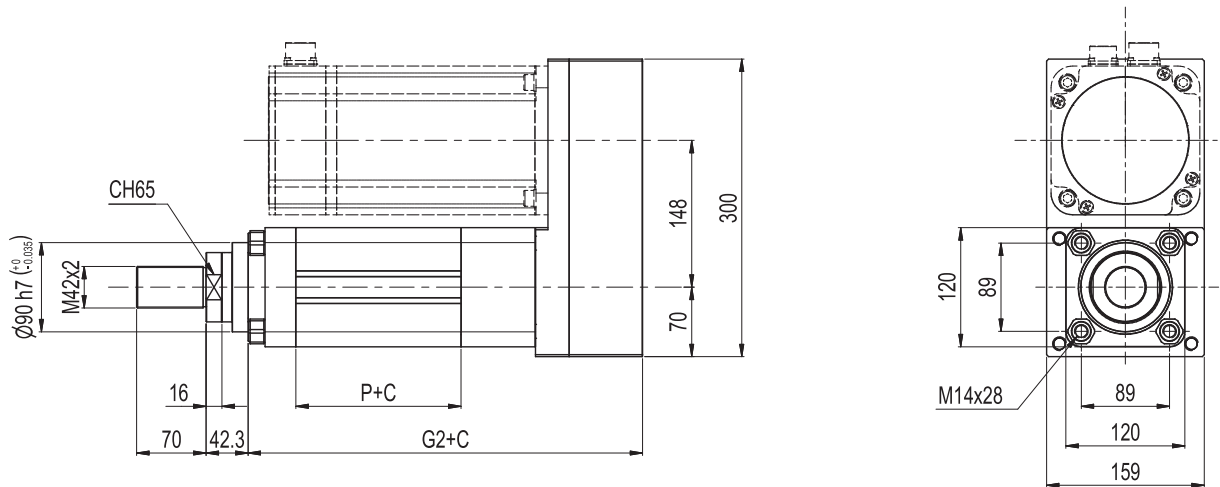

	Ball screw	P	G1	G2
ECL3	38x10	166.5	321.1	397.8
	38x20	166.5	321.1	397.8
ECS3	50x20	219.5	374.1	450.8

C = Stroke value  
V = Depending on motor dimensions



### 10 - EC\*3-125

#### 10.1 - Technical characteristics

			ECL3	ECS3	
Mechanical	Rod diameter	mm	85	85	
	Rod end		M48x2	M48x2	
Ball screw	Nominal diameter	mm	50	63	
	Lead	mm	20	10	20
	Dynamic load	N	98718	80148	248193
Force	Max force (torque) - in line	N (Nm)	88300 (327.1)	103800 (205.4)	123400 (462.7)
	Max force (torque) - parallel	N (Nm)	88300 (348.0)	103800 (218.5)	123400 (492.2)
	Force at 2500 km (*)	N	19744	12723	49639
Speed	Maximum speed	rpm	1600	1270	1270
		mm/s	533	212	423
Acceleration	Max acceleration	m/s <sup>2</sup>	12.7	6.4	12.7
Efficiency	In line (parallel)	%	86 (81)	80 (76)	85 (80)

(\*) Dynamic axial force at 2500 km lifetime

#### 10.2 - Service life

The service life depends on average dynamic axial load.

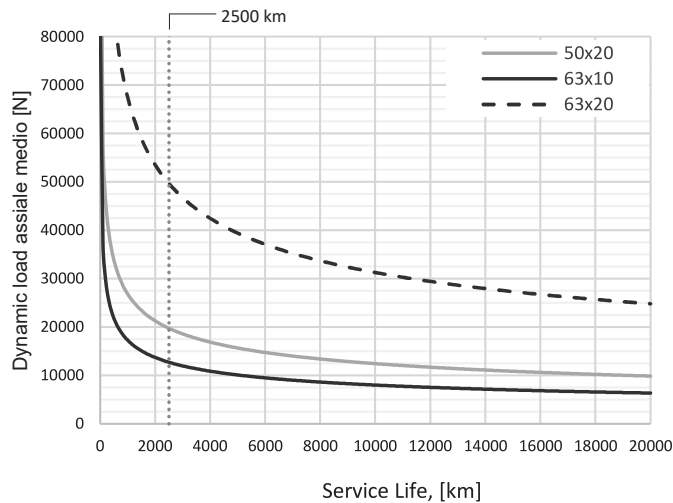

#### NOTES

- Service life is a statistical value and refers to 90% reliability.
- Correct working conditions: i.e. no lateral-load, no over-load, right lubrication, no over-temperature, no short-stroke application.
- The permissible axial force is calculated considering a pushing condition with free rod end and fixed barrel constraint. Contact us for different loading applications and for any questions.

#### 10.3 - Permissible speed

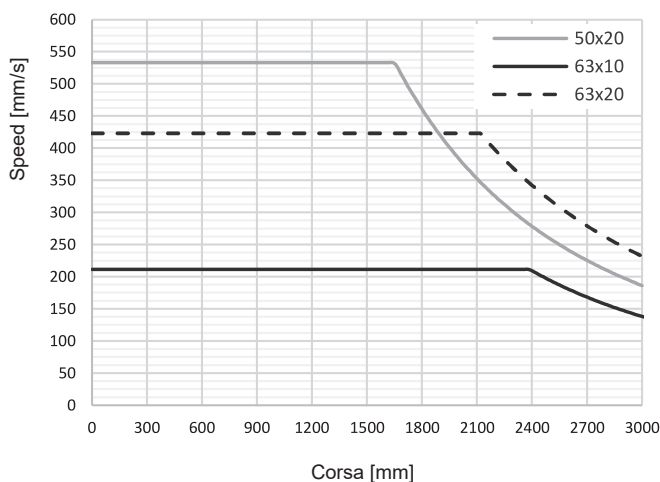

#### 10.4 - Permissible axial force

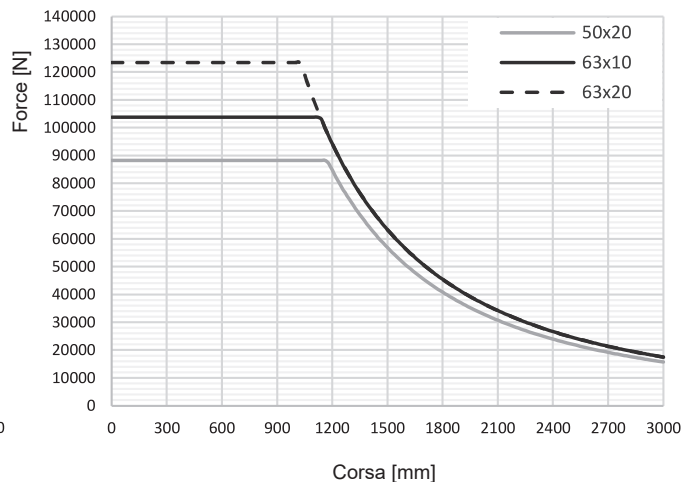



### 10.5 - EC\*3-125 - Dimensions

dimensions in mm

#### In-line motor mounting

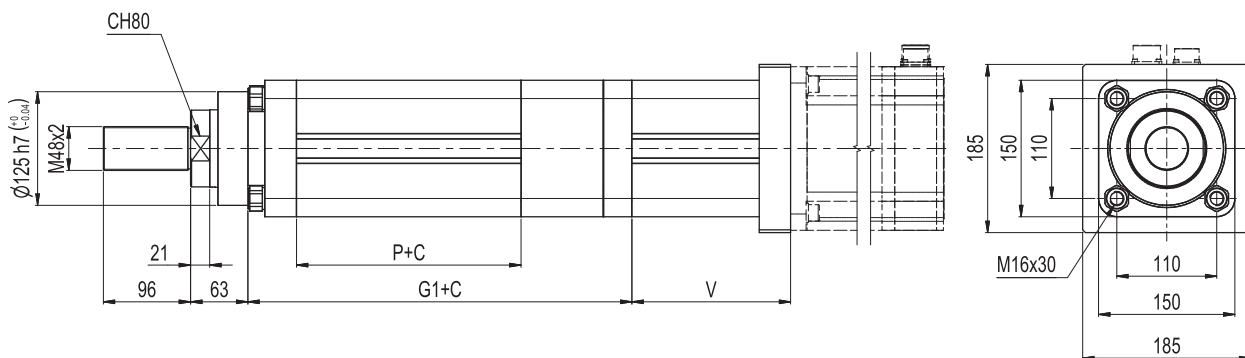

#### Parallel motor mounting

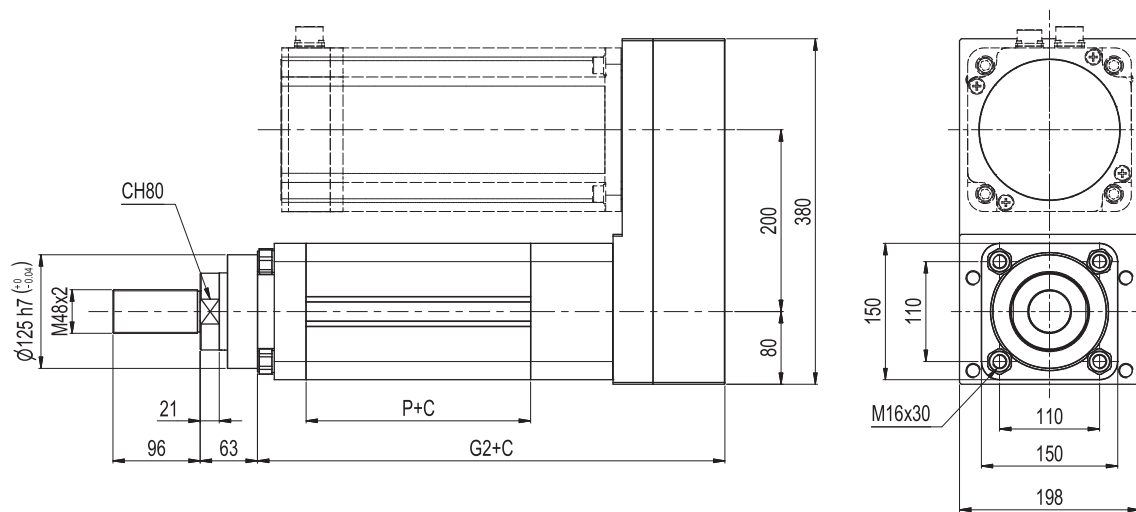

	Ball screw	P	G1	G2
ECL3	50x20	247	422.5	514.2
ECS3	63x10	177.2	352.7	444.4
	63x20	291	466.5	558.2

C = Stroke value  
V = Depending on motor dimensions



### 11 - LEAD SCREW

This type of screw is only available for ECL3-032, ECL3-050 and ECL3- 063 electric cylinders.

#### 11.1 - Technical characteristics

			ECL3		
			032	050	063
Mechanical	Rod diameter	mm	20	25	30
	Rod end		M10x1.25	M16x1.5	M16x1.5
Lead screw	Nominal diameter	mm	14	16	20
	Lead	mm	4	4	4
Force / torque	Max force (torque) - in line	N (Nm)	2104 (3.3)	3008 (5.1)	4520 (9.1)
	Max force (torque) - parallel	N (Nm)	2104 (3.7)	3008 (5.7)	4520 (10.1)
Efficiency	In line (parallel)	%	41 (37)	37 (34)	32 (29)

In order that the electric cylinder with lead screw operates correctly, the following operating conditions must be met:

- no side loading
- no overload
- adequate lubrication
- no overheating
- no short stroke applications

The permissible force is calculated considering thrust condition with free rod-end and fixed barrel.

#### 11.2 - Permissible axial force

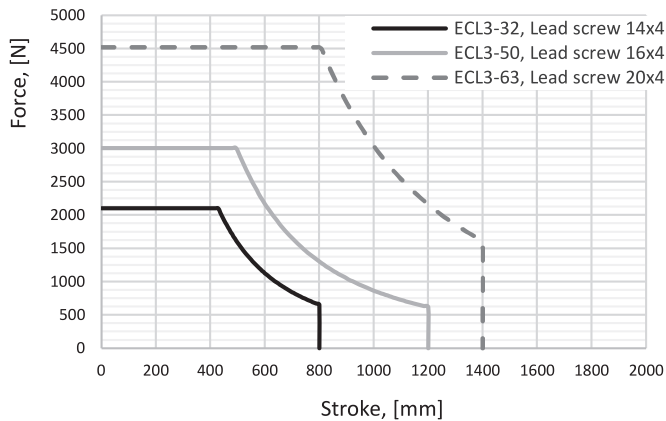



### 12 - END STROKE SENSORS

All ECL3 and ECS3 electric cylinders can be equipped with end stroke sensors, PNP or NPN type, with normally open or normally closed function. The sensors can be single or redundant, up to 4 sensors.

The end stroke sensors are housed in the side grooves of the cylinder. The sensor must then be manually arranged in the desired point.

All models are equipped with signalling LEDs.

TYPE		1	2	3	4
Logic		PNP		NPN	
Sensor type		NO	NC	NO	NC
Operating voltage	V DC	5 ÷ 30	10 ÷ 28	5 ÷ 30	10 ÷ 28
Switching current	mA	200			
Contact rating	W	6	5.5	6	5.5
Current consumption at 24V DC	mA	6	10	6	10
Max voltage drop	V	0.5 (at 200 mA)	1.5	0.5 (at 200 mA)	1.5
Leakage current	mA	0.01	0.05	0.01	0.05
Switching frequency	Hz	max 1000			
Temperature	°C	-10 / +70			
Cable		Ø2.8 PUR - 26 AWG (0.15 mm <sup>2</sup> ) - 3 wire - 3 meters length			

#### 12.1 - Wiring diagram sensor type 1 and 2

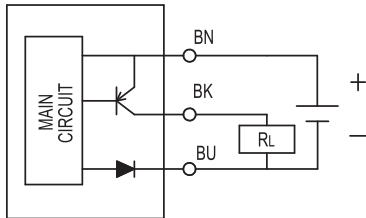

#### sensor type 3 and 4

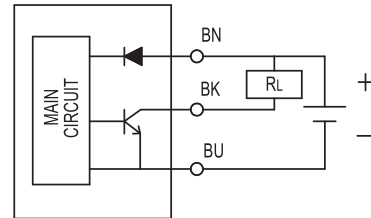

#### 12.2 - Overall dimensions

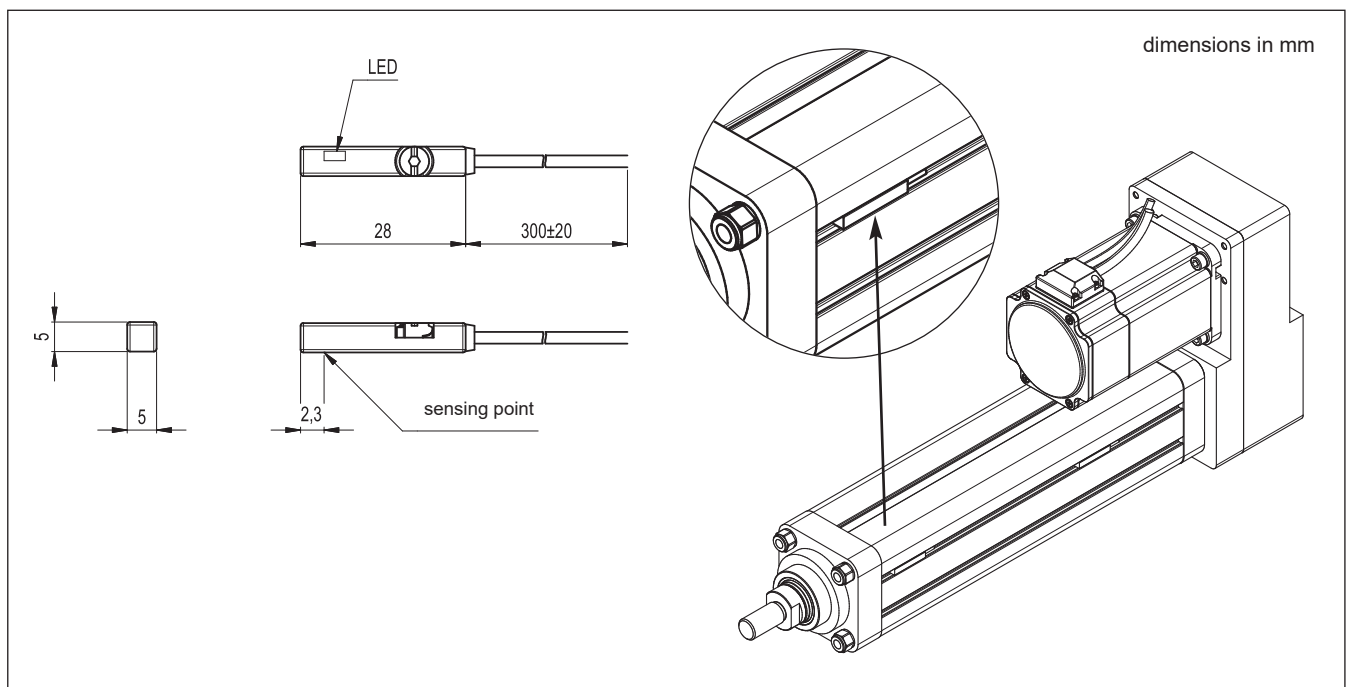



### 13 - A MOUNTING TYPE

#### A FRONT FLANGE (MF1)

dimensions in mm

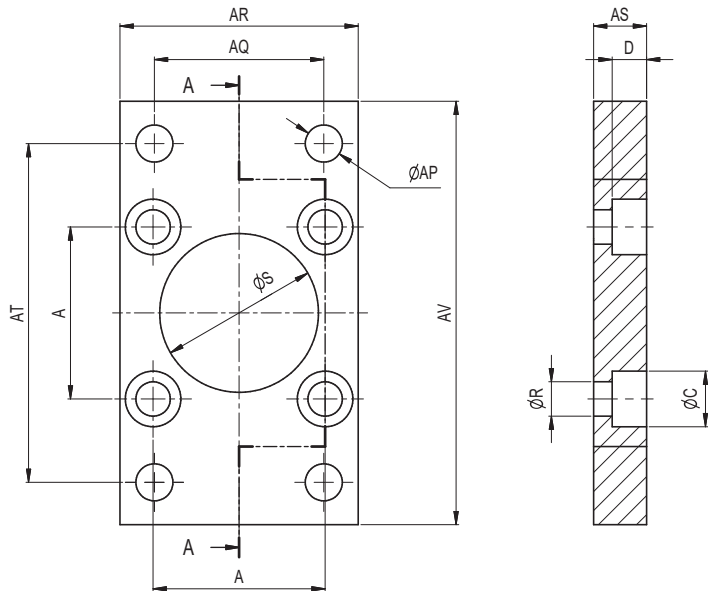

**NOTE:** Withstands the same loads as for cylinders

Size	S H11	A $\pm 0.2$	AP H13	R	AS $\pm 0.2$	AR	AQ JS14	AT JS14	AV	C	D
FFP-032	30	32.5	7	6.5	10	45	32	64	80	10.5	6.5
FFP-040	35	38	9	6.5	10	52	36	72	90	10.5	6.5
FFP-050	40	46.5	9	8.5	12	65	45	90	110	13.5	8.5
FFP-063	45	56.5	9	8.5	12	75	50	100	120	13.5	8.5
FFP-080	60	72	12	12.5	18	95	63	126	150	19	13
FFP-100	90	89	14.5	14.5	20	115	75	150	170	22	15
FFP-125	125	110	16.5	16.5	25	140	90	180	205	25	18



### 14 - C MOUNTING TYPE

#### C REAR CLEVIS (MP2)

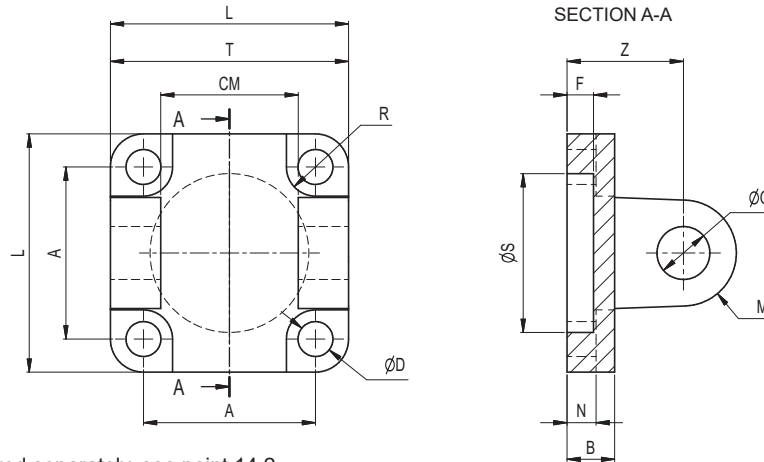

**NOTE 1:** The pin is to be ordered separately, see point 14.2

**NOTE 2:** The clevis withstands loads up to the value indicated in the table. For heavier loads please contact us.

Size	G H9	A ±0.2	L	D H13	R H13	N ±0.5	B	S H11	F	Z ±0.2	M	CM H14	T h14	Max load (N)
RPC-032	10	32.5	45	6.6	11	5.5	9	30	5	22	10	26	45	1760
RPC-040	12	38	52	6.6	11	5.5	9	35	5	25	12	28	52	3230
RPC-050	12	46.5	65	9	15	6.5	11	40	5	27	12	32	60	5150
RPC-063	16	56.5	75	9	15	6.5	11	45	5	32	16	40	70	7010
RPC-080	16	72	95	11	18	10	14	45	5	36	16	50	90	12060
RPC-100	25	110	140	14	20	10	20	60	7	50	25	70	130	20220
RPC-125	30	140	180	18	26	10	20	65	7	55	25	90	170	32730

#### 14.1 - Rear Square Brackets

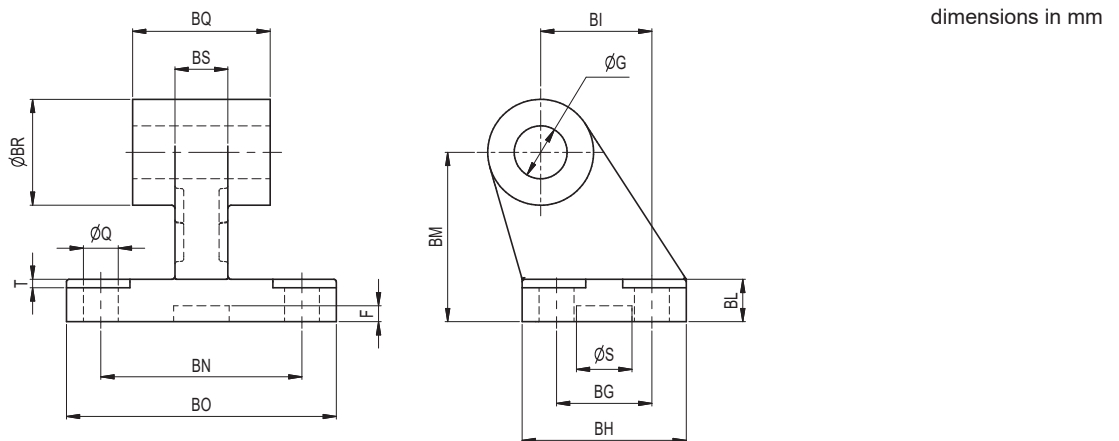

Please contact us for heavier loads.

Type	Size	G H9	Q H13	M H13	BG JS14	BH max	BI JS14	BL	BM JS15	BN JS14	BO max	BS max	BR max	T max	S +0.5 0	F +0.5 0	BQ -0.2 -0.6	Max load (N)
SBP-032	032	10	6.6	11	18	31	21	8	32	38	51	10	20	1.6	10.5	3	26	1440
SBP-040	040	12	6.6	11	22	35	24	10	36	41	54	10	22	8.5	20	3	28	1960
SBP-050	050	12	9	15	30	45	33	12	45	50	65	16	26	1.6	10.5	3	32	5520
SBP-063	063	16	16	15	35	50	37	12	50	52	67	14	30	10.5	20	3	40	5110
SBP-080	080	16	11	18	40	60	47	14	63	66	86	20	30	2.5	10.5	3	50	11310
SBP-100	100	25	14	20	60	90	70	20	90	94	124	30	45	3.2	10.5	3	70 (*)	18180
SBP-125	125	30	14	20	88	126	97	25	115	118	156	36	63	4	-	-	90 (*)	30920

(\*) Tolerance value  $\begin{matrix} -0.5 \\ -1.2 \end{matrix}$



### 14.2 - Pin for Rear Clevis

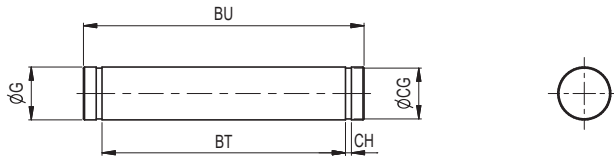

Type	Size	G e8	BT +0.3 0	CG	CH H13	BU
PNP-032	032	10	46	9.6	1.1	53
PNP-040	040	12	53	11.5	1.1	60
PNP-050	050	12	61	11.5	1.1	68
PNP-063	063	16	71	15.2	1.1	78
PNP-080	080	16	91	15.2	1.1	98
PNP-100	100	25	132	23.9	1.3	139
PNP-125	125	30	171.5	28.6	1.6	178

NOTE: It withstands the same loads as the related accessories.

### 15 - D MOUNTING TYPE

#### D REAR EYE (MP4)

dimensions in mm

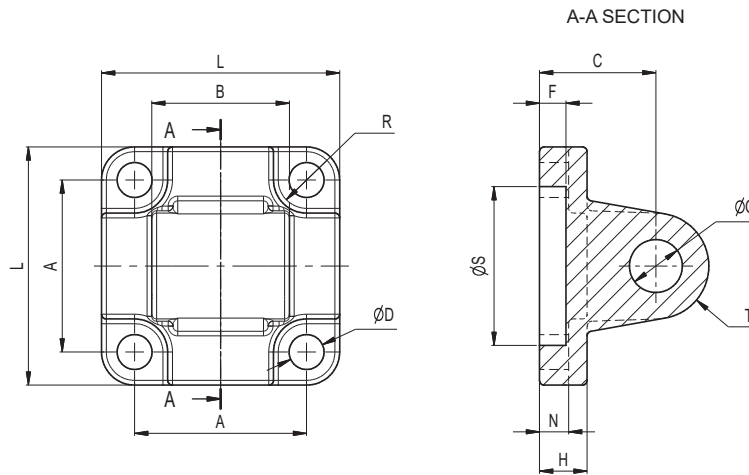

NOTE: Please contact us for heavier loads.

Type	G H9	A $\pm 0.2$	L	D H13	R H13	N $\pm 0.5$	H	S H11	F	C $\pm 0.2$	T max	B $-0.2$ $-0.6$	Max load (N)
REP-032	10	32.5	45	6.6	11	5.5	9	30	5	22	10	26	2410
REP-040	12	38	52	6.6	11	5.5	9	35	5	25	12	28	3770
REP-050	12	46.5	65	9	15	6.5	11	40	5	27	12	32	5890
REP-063	16	56.5	75	9	15	6.5	11	45	5	32	16	40	9550
REP-080	16	72	95	11	18	10	14	45	5	36	16	50	15080
REP-100	25	110	140	14	20	10	20	60	7	50	25	70	23560
REP-125	30	140	180	18	26	10	26	65	7	55	25	90	36820



### 16 - G MOUNTING TYPE

G FEET (MS1)

dimensions in mm

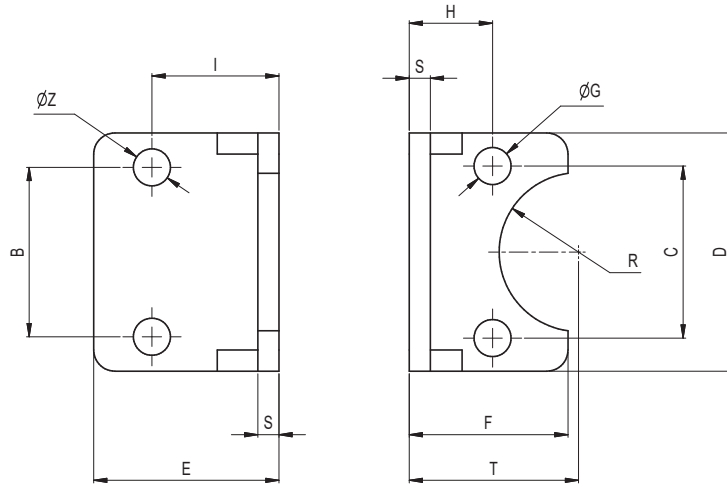

**NOTE:** Do not use to withstand load. Please contact us for a technical analysis if the application force should apply to this accessory.

Type	Size	C ± 0.2	B JS14	D 0 -0.2	E	F +2 0	G H14	H ± 0.2	I ± 0.2	S ± 0.5	T JS15	R H15	U	Z H14
FTP-032	032	32.5	32	45	35	30	7	15.75	24	4	32	15	11	7
FTP-040	040	38	36	52	36	30	7	17	28	4	36	17.5	15	9
FTP-050	050	46.5	45	65	47	36	9	21.75	32	5	45	20	16	9
FTP-063	063	56.5	50	75	45	35	9	21.75	32	5	50	22.5	18	9
FTP-080	080	72	063	95	55	47	12.5	27	41	6	63	30	17	12.5
FTP-100	100	89	75	115	57	53	14.5	26.5	41	6	71	45	24	14.5
FTP-125	125	110	90	140	70	70	16.5	35	45	8	90	62.5	-	16.5

### 17 - L MOUNTING TYPE

L INTERMEDIATE TRUNNIONS (MT4)

dimensions in mm

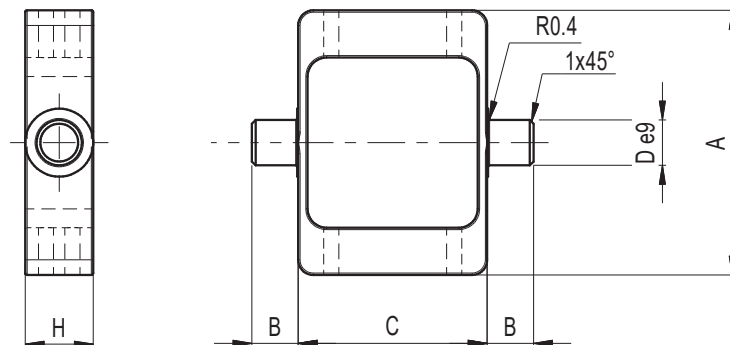

**NOTE 1:** Side fixing brackets are to be ordered separately, see point 17.1

Type	Size	A	B	C	D	H
TRP-032	032	70	12	50	12	18
TRP-040	040	78	16	62	16	20
TRP-050	050	91	16	74	16	20
TRP-063	063	94	20	88	20	25
TRP-080	080	130	20	109	20	25
TRP-100	100	145	25	130	25	30
TRP-125	125	154	25	155	25	32

**NOTE 2:** Do not use to withstand load. Please contact us for a technical analysis if the application force should apply to this accessory.



### 17.1 - Side Fixing Brackets

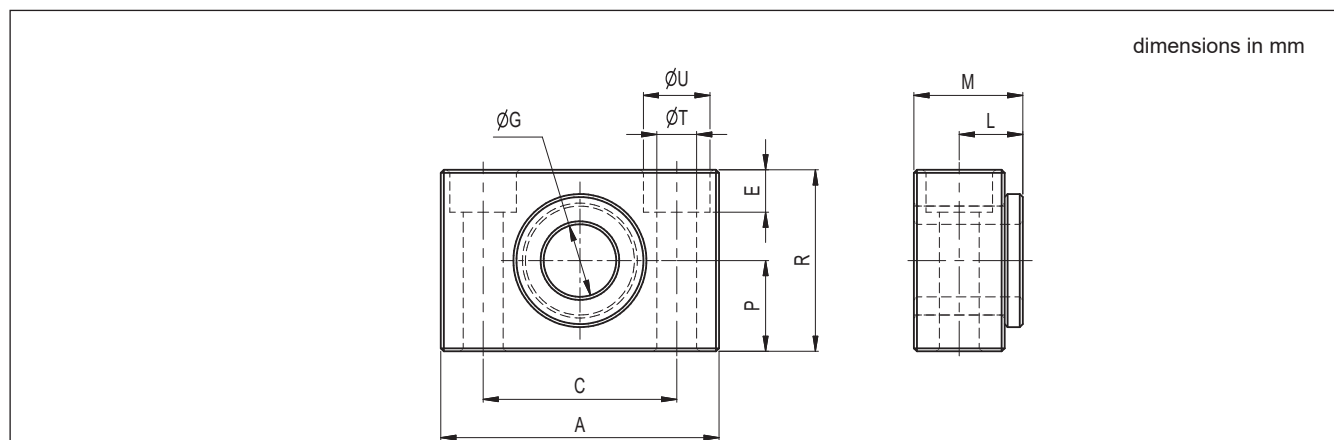

**NOTE:** Do not use to withstand load.  
Please contact us for a technical analysis if the application force should apply to this accessory.

Type	Size	G F7	A	M	R	P ±0.1	C ±0.2	L	U H13	T H13	E ±0.5
BRP-12	032	12	46	18	30	15	32	10.5	11	6.6	7
BRP-16	040	16	55	21	36	18	36	12	15	9	9
	050	16	55	21	36	18	36	12	15	9	9
BRP-20	063	20	65	23	40	20	42	13	18	11	11
	080	20	65	23	40	20	42	13	18	11	11
BRP-25	100	25	75	28.5	50	25	50	16	20	14	13
	125	25	75	28.5	50	25	50	16	20	14	13

### 18 - OVERALL MOUNTING DIMENSIONS FOR ROD-END

#### 18.1 - Female Thread

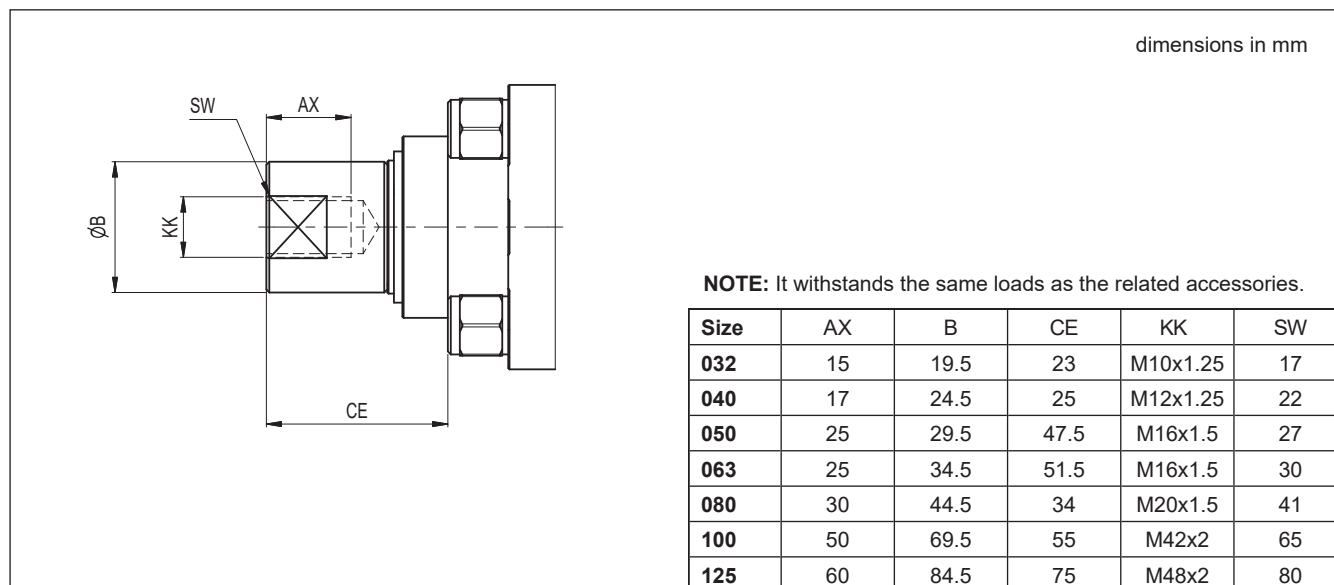



### 18.2 - Clevis (ISO 8140)

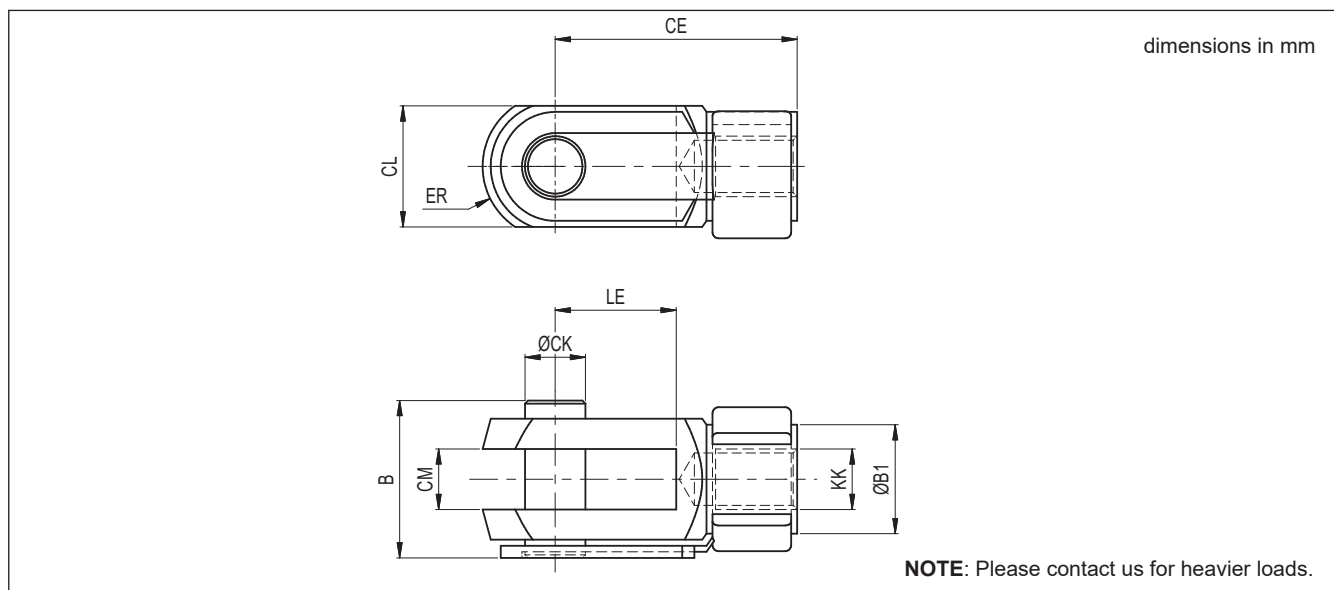

Type	Size	KK	CK	LE	CM	CL	ER	CE	B	B1	Max load (N)
CLP-M10	032	M10x1.25	10	20	10	20	12	40	26	18	5000
CLP-M12	040	M12x1.25	12	24	12	24	14	48	32	20	7200
CLP-M16	050	M16x1.5	16	32	16	32	19	64	40	26	12800
CLP-M16	063	M16x1.5	16	32	16	32	19	64	40	26	12800
CLP-M20	080	M20x1.5	20	40	20	40	25	80	48	34	20000
CLP-M42	100	M42x2	40	84	40	85	64	168	104.3	70	88750
CLP-M48	125	M48x2	50	96	50	96	73	192	117.3	82	102500

### 18.3 - Spherical Eye (ISO 8139)

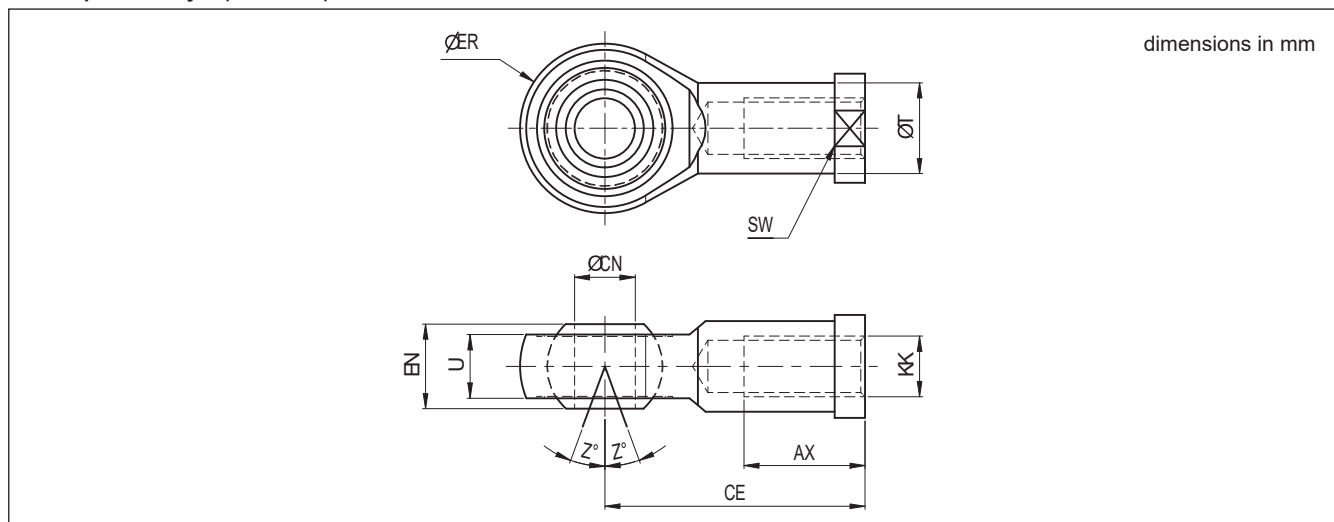

Type	Size	KK	CN	U	EN	ER	AX	CE	T	Z	SW	Max load (N)
SPP-M10	032	M10x1.25	10	10.5	14	28	20	43	15	6.5	17	3500
SPP-M12	040	M12x1.25	12	12	16	32	22	50	17.5	6.5	19	4750
SPP-M16	050	M16x1.5	16	15	21	42	28	64	22	7.5	22	12000
SPP-M16	063	M16x1.5	16	15	21	42	28	64	22	7.5	22	12000
SPP-M20	080	M20x1.5	20	18	25	50	33	77	27.5	7	30	13000
SPP-M42	100	M42x2	40	33	49	91	60	142	53	8	55	65000
SPP-M48	125	M48x2	50	45	60	117	65	162	65	7	65	77000

